

Modellname: **LIMA**
 Nazwa modelu:

Modellreihe: **4014--20**
 Numer modelu:

Type: **20**
 Typ:

Blatt Nr 1 von: 5
 Strona z:



Tabelle mit Maßen/Menge und Colli-Nr. der Einzelteile

NO	Dim.	Col.-No	Qty
1, 2	1015 378	1	2
3	1922 396	1	1
4	2000 420	1	1
5, 6	919 381	1	2
7	561 100	1	3
8	277 364	1	1
9L, 9R	1015 68	1	2
10	1985 80	1	1
11L, 11R	412 80	1	2
12	1922 78	1	1
13	365 78	1	2
14	1817 80	1	1
15	658 355	2	4
16	931 581	1	1
16L, 16R	931 674	1	2
17	555 190	2	3
18	521 140	2	3
19L, 19R	352 140	2	10
20	532 350	2	3
21L, 21R	276 190	2	2
22	233 140	2	2
23	244 350	2	2
24	832 601	2	2



x2
 24

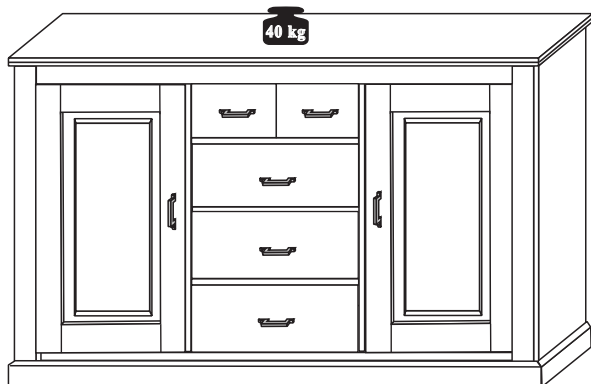
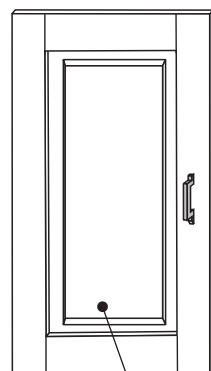
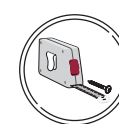
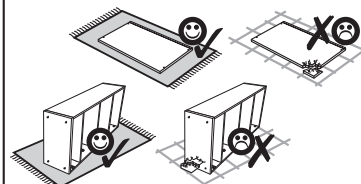
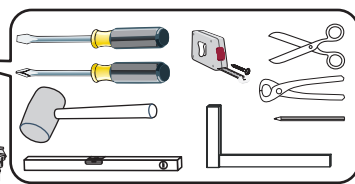
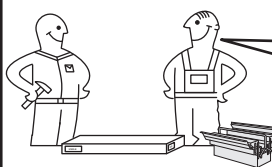
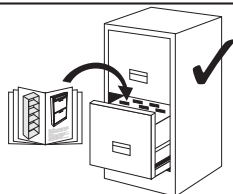
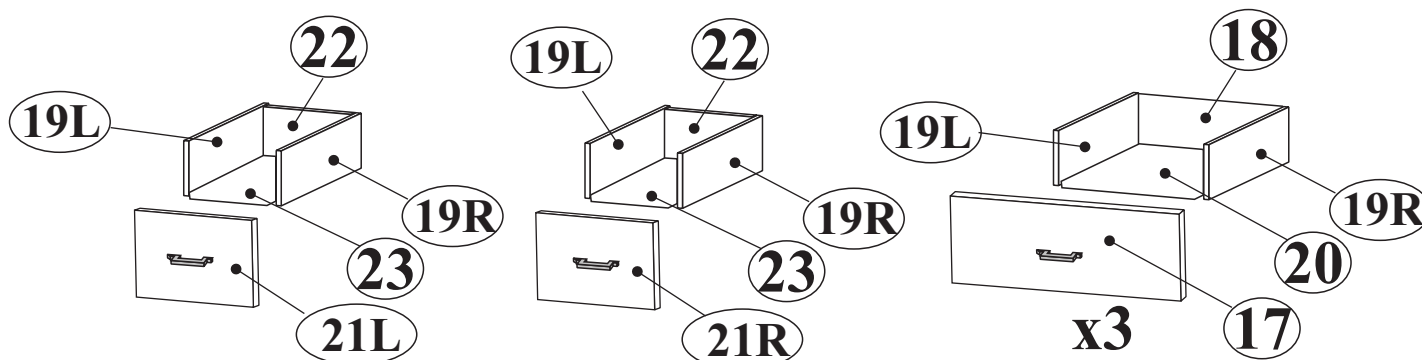
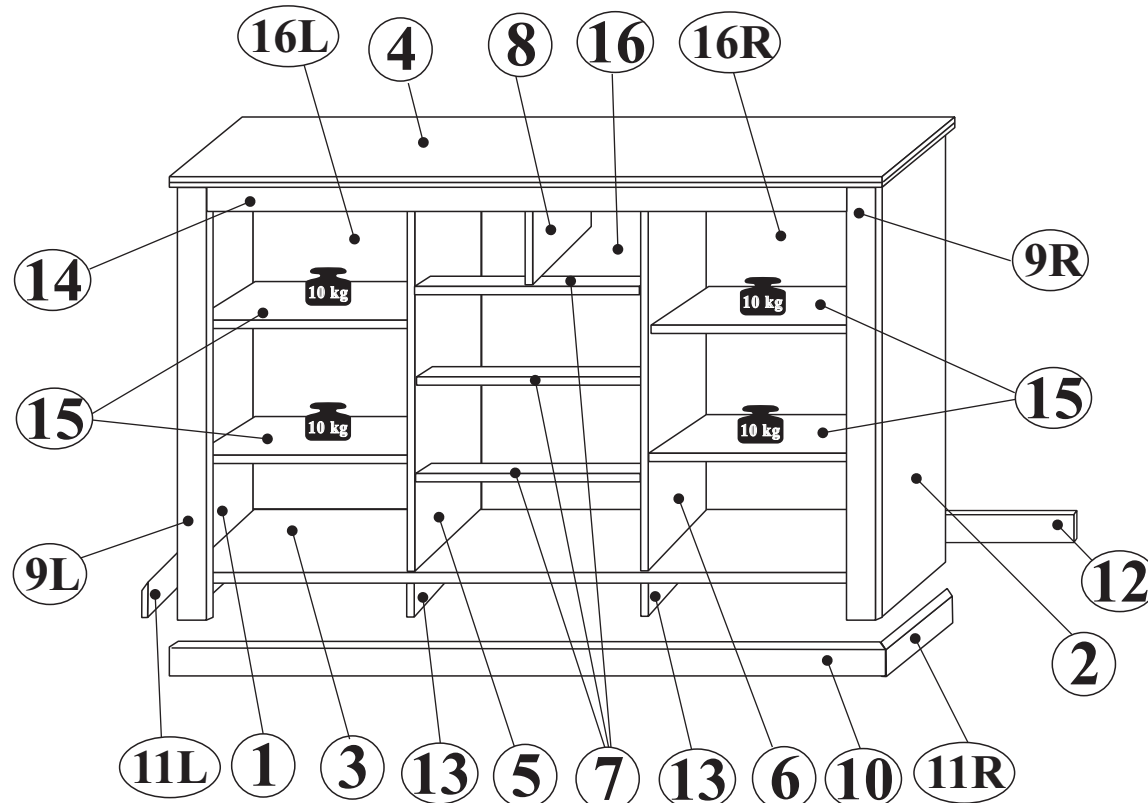

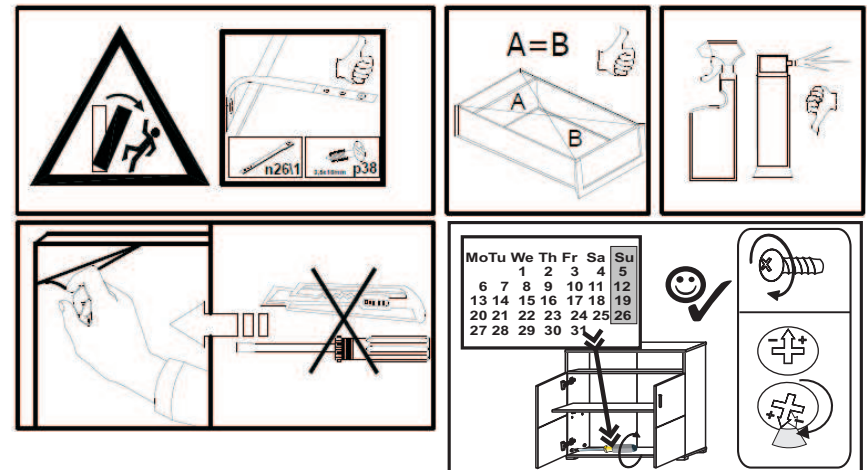
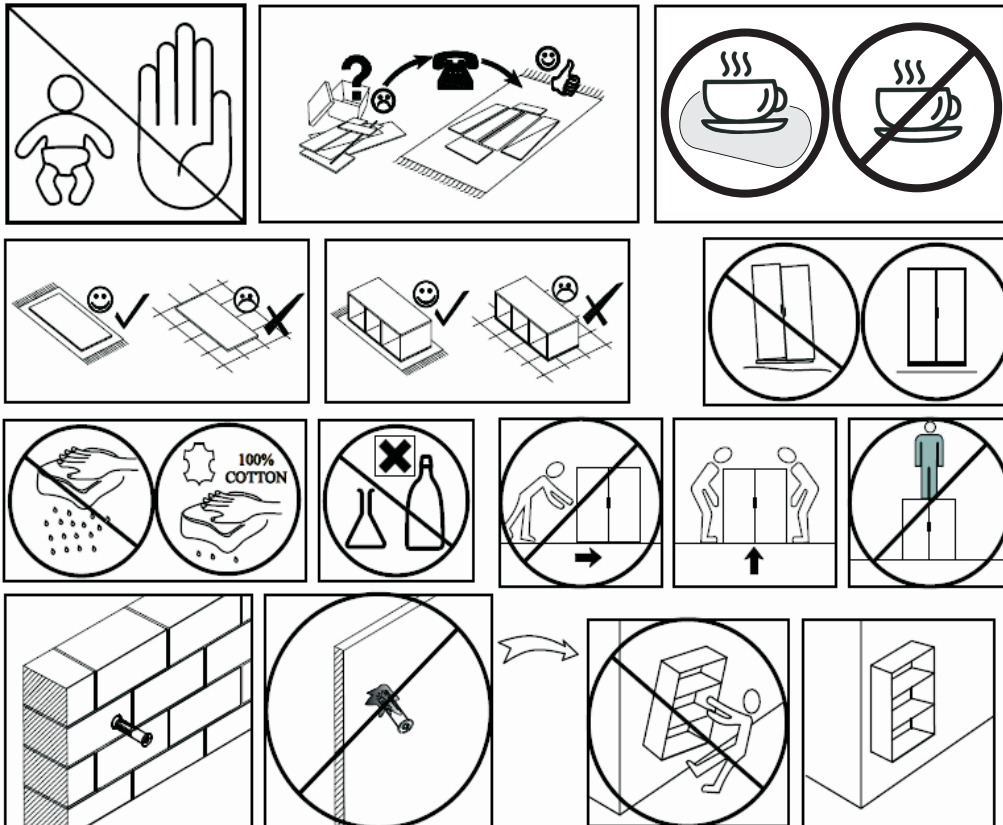
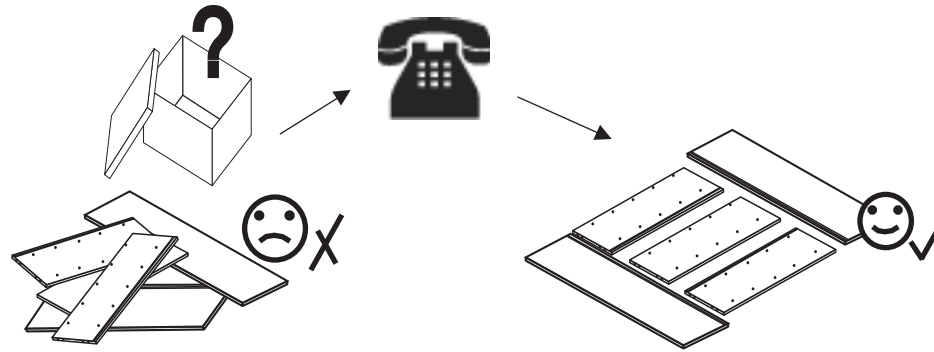

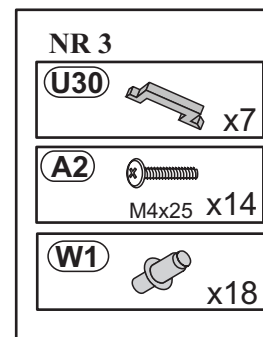
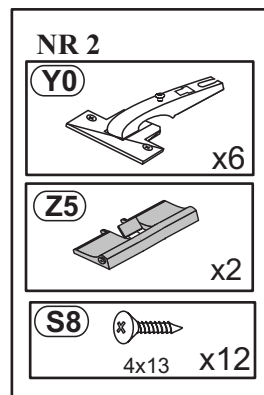
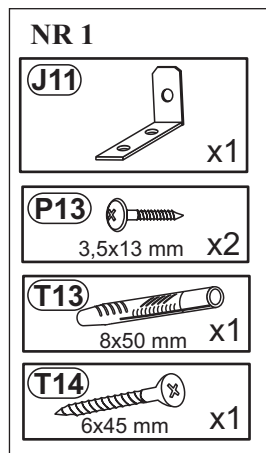

Modellname: **LIMA**
Nazwa modelu:

Modellreihe: **4014--20**
Numer modelu:

Type: **20**
Typ:

Blatt Nr **4** von: **5**
Strona z:

1

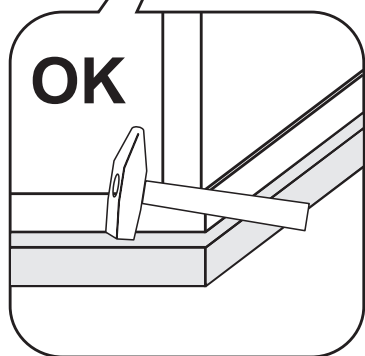
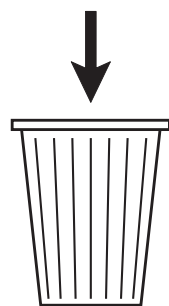
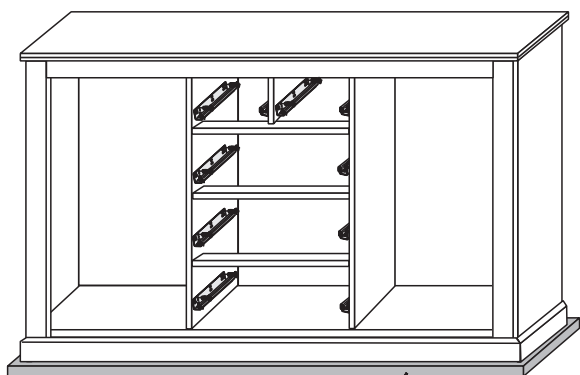

2

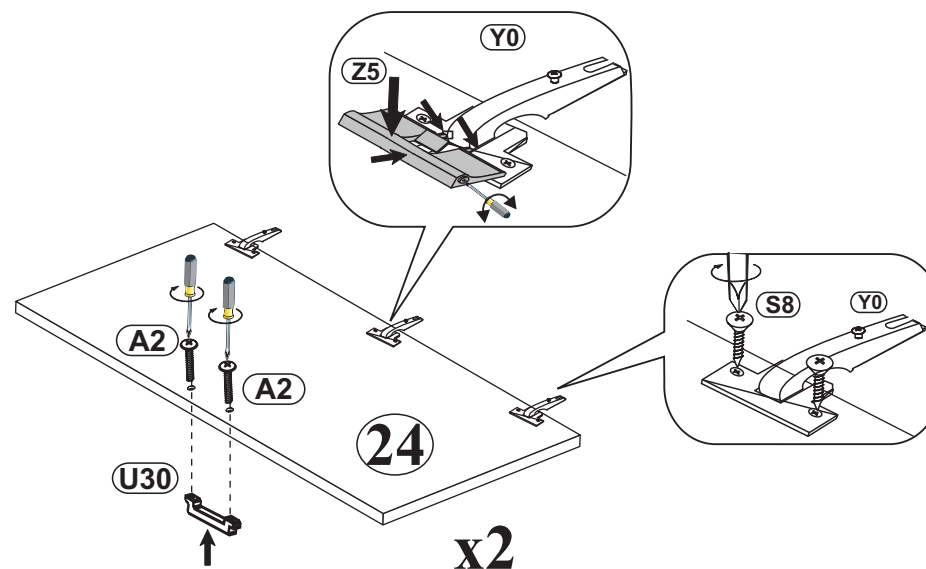
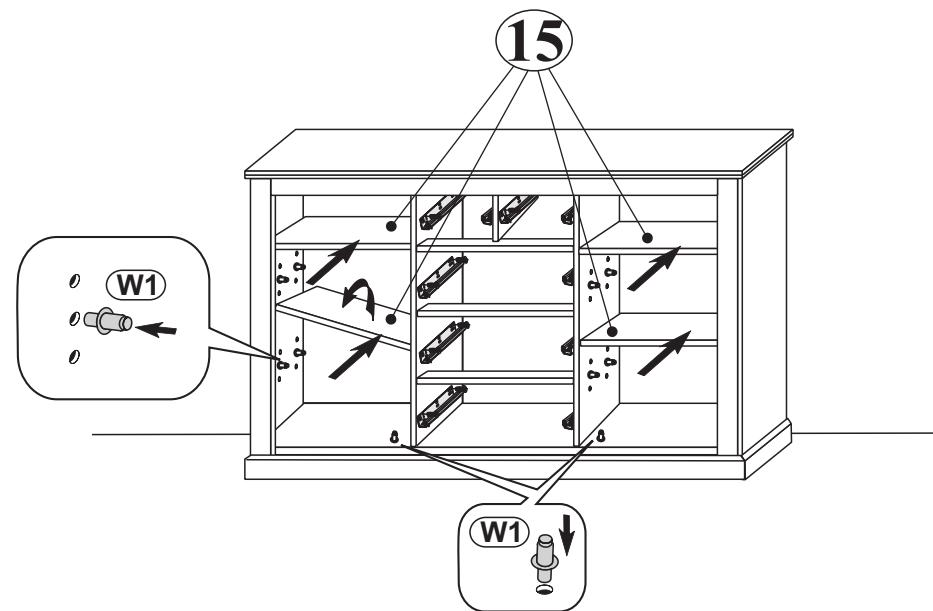
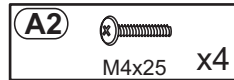
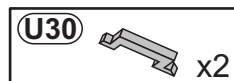
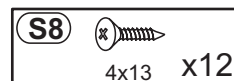
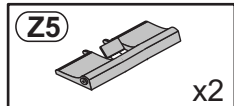
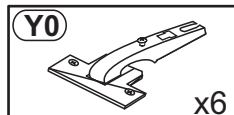
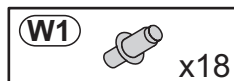

3

